

BKR: 3-way regulating ball valve with female thread, PN 40

How energy efficiency is improved

Efficiency means precise control and working with minimum leakage

Features

- 3-way regulating ball valve for continuous control of cold and hot water in closed circuits
- In combination with valve actuators AKM 105(S), 115(S), 115SA and AKF 112, 113(S) as a control unit
- Control contour in the ball directly integrated
- Control passage characteristic can be set to linear or quadratic with SUT rotary actuator
- Low torque due to collar mounted on O-ring
- Spindle with large sliding surface and PTFE ring
- Ball valve with female thread as per ISO 7/1 Rp or NPT
- Body made of DZR (dezincification-resistant) cast brass
- Spindle made of DZR brass with PTFE glide ring
- Ball made of DZR brass, chrome-plated and polished surface
- Spindle seal with double O-ring made of EPDM
- Strainer and screw fitting available as accessories
- Water quality as per VDI 2035

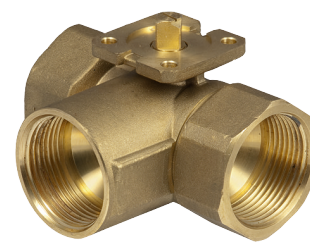

BKR025F310

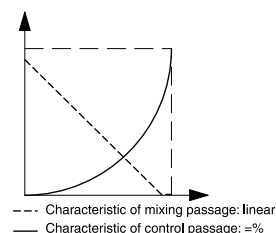

Technical data

Parameters

Nominal pressure	40 bar
K_{VS} value, mixing passage	-10...-30% through the control passage
Valve characteristic, control passage	Equal-percentage
Valve characteristic, mixing passage	Linear
Control ratio of ball valve	500:1
Control ratio with actuator	Approx. 50:1
Leakage rate, control passage	Watertight as per EN 60534-4 L/1, better than class 4
Leakage rate, mixing passage	< 1%
Angle of rotation	90°

Ambient conditions

Operating temperature ¹⁾	-10...130 °C, no condensation
Operating pressure	40 bar (-10...50 °C) 35 bar (130 °C)

Overview of types

Type	Nominal diameter	Connection ISO 7/1 Rp	K_{VS} value, control pas- sage	Weight
BKR015F340-FF	DN 15	Rp ½"	1.6 m³/h	0.31 kg
BKR015F330-FF	DN 15	Rp ½"	2.5 m³/h	0.31 kg
BKR015F320-FF	DN 15	Rp ½"	4 m³/h	0.31 kg
BKR015F310-FF	DN 15	Rp ½"	6.3 m³/h	0.33 kg
BKR020F320-FF	DN 20	Rp ¾"	4 m³/h	0.4 kg
BKR020F310-FF	DN 20	Rp ¾"	6.3 m³/h	0.4 kg
BKR025F310-FF	DN 25	Rp 1"	10 m³/h	0.63 kg
BKR032F310-FF	DN 32	Rp 1¼"	16 m³/h	0.97 kg
BKR040F310-FF	DN 40	Rp 1½"	25 m³/h	1.4 kg
BKR050F310-FF	DN 50	Rp 2"	40 m³/h	2.67 kg

¹⁾ At operating temperatures <5 °C and >100 °C, the appropriate accessories must be used.



Accessories

Type	Description
0510240001	Assembly kit for VK**/BK** ball valves as spare part and as accessory for rotary actuators ASF 112, 113 from index B
0510240011	Adaptor required when temperature of the medium < 5 °C
0510420001	Adaptor required when temperature of the medium > 100 °C
0560284015	Screw fitting in brass, flat-sealing, female thread/male thread for DN 15
0560284020	Screw fitting in brass, flat-sealing, female thread/male thread for DN 20
0560284025	Screw fitting in brass, flat-sealing, female thread/male thread for DN 25
0560284032	Screw fitting in brass, flat-sealing, female thread/male thread for DN 32
0560284040	Screw fitting in brass, flat-sealing, female thread/male thread for DN 40
0560284050	Screw fitting in brass, flat-sealing, female thread/male thread for DN 50
0560332015	Strainer in gun metal (bronze), -10...150 °C, mesh aperture 0.5 mm, DN 15
0560332020	Strainer in gun metal, -10...150 °C, mesh aperture 0.8 mm, DN 20
0560332025	Strainer in gun metal (bronze), -10...150 °C, mesh aperture 0.8 mm, DN 25
0560332032	Strainer in gun metal, -10...150 °C, mesh aperture 0.8 mm, DN 32
0560332040	Strainer in gun metal, -10...150 °C, mesh aperture 0.8 mm, DN 40
0560332050	Strainer in gun metal, -10...150 °C, mesh aperture 0.8 mm, DN 50

 1 unit delivered in each case, unless otherwise specified. See last page for dimensions and scope of delivery of accessories.

Combination of BKR with electric actuators

i *Warranty: The technical data and pressure differences indicated here are applicable only in combination with SAUTER valve actuators. The warranty does not apply if used with valve actuators from other manufacturers.*

i *Definition of Δp_{max} : Maximum admissible pressure drop in control mode at which the actuator reliably opens and closes the ball valve.*

Pressure differences

Actuator	AKM105F100 AKM105F120	AKM105F122	AKM115F120	AKM115F122
Rotational torque	4 Nm	4 Nm	8 Nm	8 Nm
Control signal	2-/3-point	2-/3-point	2-/3-point	2-/3-point
Running time	30/120 s	30/120 s	120 s	120 s
Operating voltage	230 VAC	24 VAC	230 VAC	24 VAC
As control valve	Δp_{max} [bar]	Δp_{max} [bar]	Δp_{max} [bar]	Δp_{max} [bar]
BKR015F340-FF BKR015F330-FF BKR015F320-FF BKR015F310-FF BKR020F320-FF BKR020F310-FF BKR025F310-FF	1.8	1.8	2.0	2.0
BKR032F310-FF BKR040F310-FF BKR050F310-FF	1.2	1.2	2.0	2.0

Cannot be used as distribution valve

Actuator	AKM105SF132	AKM115SF132	AKM115SAF232	AKM115SF152
Rotational torque	4 Nm	8 Nm	8 Nm	7 Nm
Control signal	2-/3-point, 0...10 V	2-/3-point, 0...10 V	0...10 V, BACnet MS/TP	2-/3-point, 0...10 V, 4...20 mA
Running time	35/60/120 s	35/60/120 s	35/60/120 s	6 s
Operating voltage	24 VAC/DC	24 VAC/DC	24 VAC/DC	24 VAC/DC
As control valve	Δp_{\max} [bar]	Δp_{\max} [bar]	Δp_{\max} [bar]	Δp_{\max} [bar]
BKR015F340-FF BKR015F330-FF BKR015F320-FF BKR015F310-FF BKR020F320-FF BKR020F310-FF BKR025F310-FF	1.8	2.0	2.0	2.0
BKR032F310-FF BKR040F310-FF BKR050F310-FF	1.2	2.0	2.0	2.0

Cannot be used as distribution valve

Actuator	AKF112F120	AKF112F122	AKF113F122	AKF113SF122				
Rotational torque	7 Nm	7 Nm	7 Nm	7 Nm				
Control signal	2-point	2-point	3-point	0...10 V				
Running time	90 s	90 s	90 s	90 s				
Operating voltage	230 VAC	24 VAC/DC	24 VAC/DC	24 VAC/DC				
As control valve	Δp_{\max} [bar]	Δp_s [bar]	Δp_{\max} [bar]	Δp_s [bar]	Δp_{\max} [bar]	Δp_s [bar]	Δp_{\max} [bar]	Δp_s [bar]
BKR015F340-FF BKR015F330-FF BKR015F320-FF BKR015F310-FF BKR020F320-FF BKR020F310-FF BKR025F310-FF	2.0	5.4	2.0	5.4	2.0	5.4	2.0	5.4
BKR032F310-FF BKR040F310-FF BKR050F310-FF	2.0	3.5	2.0	3.5	2.0	3.5	2.0	3.5

Cannot be used as distribution valve

Description of operation

The 3-way regulating ball valve is designed for the continuous control of cold and domestic hot water in closed circuits and may only be used for this purpose.

The 3-way regulating ball valve can be moved to any intermediate position with an electric actuator. A mixing function can be implemented with actuators AKM 105, 115(S) and 115SA, as well as actuators with spring return AKF 112 and 113(S). A distribution function is not admissible.



These 3-way regulating ball valves are characterised by their reliability and precision and make an important contribution towards environmentally friendly regulation. They meet difficult challenges such as the quick-closing function, overcoming differential pressures, controlling media temperatures and performing the shut-off function, all with a low noise level.

The spindle of the ball valve is automatically connected to the spindle carrier of the actuator. The brass ball controls the equal-percentage flow rate in the control passage and the linear flow rate in the mixing passage. The tightness of the ball is ensured by the PTFE collars incorporated in the body. An O-ring made of EPDM is inserted behind these two collars in the control passage. These O-rings enable the ball and the two collars to make a small axial movement, providing a high level of tightness and small torques.

The tightness of the spindle is ensured by two O-rings. These cannot be replaced.

Intended use

This product is only allowed to be used in HVAC building systems for control and regulation purposes. Other uses require the prior consent of the manufacturer.

The section "Description of operation" and all product instructions in this data sheet must be observed.

Modifying or converting the product is not permitted.

Improper use

The BKR regulating ball valve does not have drinking water approval.

The product is not suitable for use in potentially explosive atmospheres.



Notice in accordance with California Proposition 65

The product contains lead. To be marketed in North America, the appropriate warnings must be affixed to the product or packaging.

Engineering and fitting notes

The 3-way regulating ball valves are combined with rotary actuators with or without a spring return. The actuator is mounted directly on the ball valve and fastened with a bayonet connector. The actuator shaft is automatically connected to the spindle, whereby the stem of the ball valve is in an intermediate position. When the system is commissioned, the SUT actuator moves to the control passage open position, and the two devices are connected automatically. The angle of rotation of the ball valve is also detected by the actuator, and no further adjustments are required. With the SUT actuators, the characteristic of the control passage can be set to linear or quadratic as required. To avoid the ball valve being jammed in the end positions, the SUT actuator makes a movement of approx. 30° angle of rotation if the end positions of the positioning signal have not changed within three days.

So that impurities are retained in the water (welding beads, rust particles, etc.) and the PTFE collar is not damaged, it is necessary to install dirt filters, for example one for each floor or pipe run. For dirt filters, see the accessories, and note the usage and temperature range for each type. Requirements for water quality as per VDI 2035.

All ball valves must be used in closed circuits only. In open circuits, an excessively high oxygen mixture can destroy the ball valves. To avoid this, an oxygen binding agent must be used; here the compatibility must be clarified with the manufacturer of the solution with regard to corrosion. The material list shown below may be used here.

The fittings are usually insulated in the systems. However, note that the flange into which the actuator is inserted is not insulated.

To prevent any disturbing flow noise from being audible in quiet rooms, the pressure difference over the ball valve must not exceed 50% of the specified values.

The crank handle is fixed to the actuator. To operate this crank handle, the manual adjustment knob on the actuator must be pushed downwards. The actuator remains inactive until this knob is shifted into the top position again. There is also a squared end on the crank handle that matches the squared end on the spindle of the ball valve.

Additional technical data

Pressure and temperature data	EN 764, EN 1333
Flow parameters	EN 60534, page 3
Technical manual on control units	7000477001
Parameters, fitting notes, control, general information	Applicable EN, DIN, and AD standards, TRD rules and accident prevention regulations
CE conformity: PED 2014/68/EU	Fluid group II, no CE label as per PED, art. 4.3
UKCA conformity: Pressure Equipment (Safety) Regulations 2016	Fluid group II, no UKCA label as per PE(S)R, art. 8(3)

Using with water

When using water mixed with glycol or an inhibitor, the compatibility of the materials and seals used in the ball valve should be clarified with the manufacturer. The material list in the Declaration on materials and the environment MD 56.091 can be used for this purpose. When glycol is used, we recommend using a concentration of between 20% and 50%.

Fitting position

The control unit can be fitted in any position, but the hanging position is not recommended. Condensate, drops of water, etc. must be prevented from entering the actuator.

Flow-rate chart

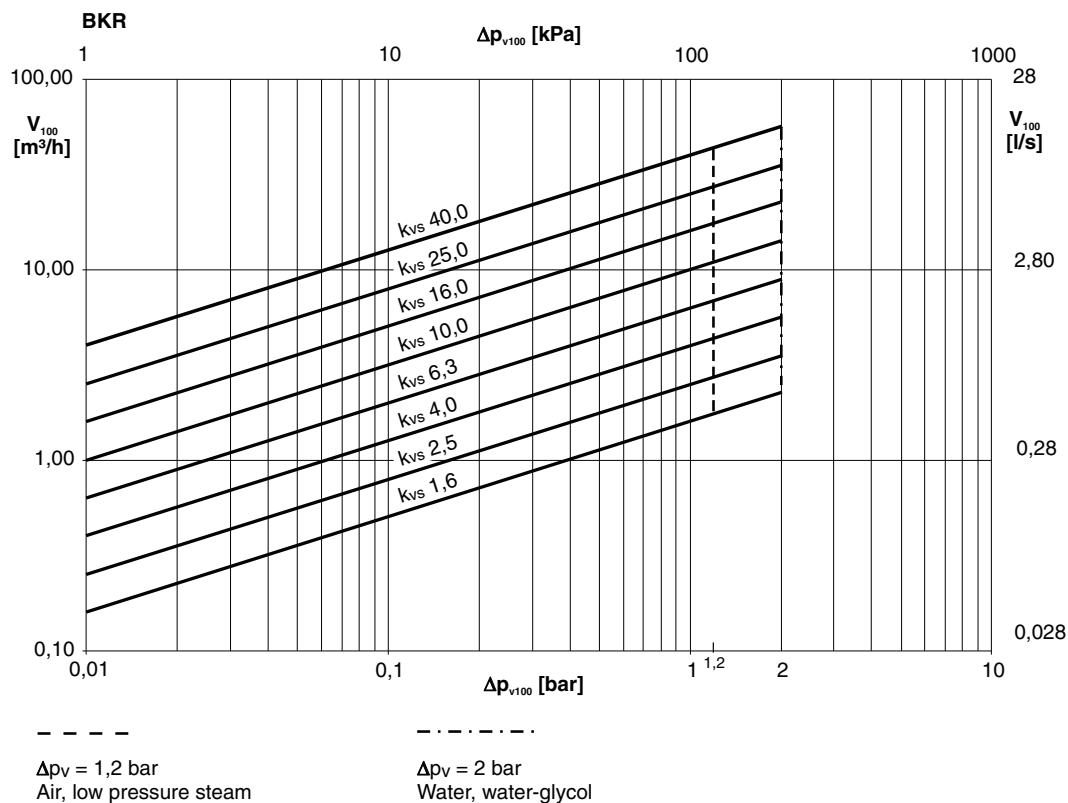

Additional version information

The body of the ball valve is made of DZR moulded brass (EN 12165) with female thread, cylindrical, as per ISO 7/1 Rp. Spindle seal with double O-ring made of ethylene propylene.

Material numbers as per DIN

Component	DIN material no.	DIN designation
Body of the ball valve	CW602N	CuZn36Pb2As
Connector	CW602N	CuZn36Pb2As
Ball, polished, chrome-plated	CW602N	CuZn36Pb2As
Stem	CW602N	CuZn36Pb2As
O-ring	EPDM	–
Collar	PTFE	–

Definition of pressure differences

Δp_v : Maximum admissible pressure difference over the valve at every stroke position, limited by noise level and erosion. With this parameter, the valve is characterised as a flow element with specific hydraulic behaviour. Monitoring the cavitation and erosion along with the associated noise increases both the service life and the operational capacity.

Δp_{max} : Maximum admissible pressure difference over the valve at which the actuator can reliably open and close the valve. The following are considered: Static pressure and flow effects. This value ensures trouble-free stroke movement and tightness. The value Δp_v of the valve is never exceeded.

Δp_s : Maximum admissible pressure difference over the valve in the event of a malfunction (e.g. power failure, excessive temperature or pressure, pipe break) at which the actuator can close the valve tightly and, if necessary, maintain the entire operating pressure against atmospheric pressure. Because this is a safety function with a rapid stroke movement, Δp_s can be greater than Δp_{max} or Δp_v . The flow disturbing effects that arise here are quickly passed through. They are of secondary importance with this method of operation. For 3-way valves, the values only apply to the control passage.

Δp_{stat} : Line pressure behind the valve. This essentially corresponds to the idle pressure when the pump is switched off, caused for example by the fluid level in the system, increased pressure due to pressure tanks or steam pressure. For valves that close with pressure, the static pressure plus the pump pressure are used.

Characteristic for control passage for actuators with positioner

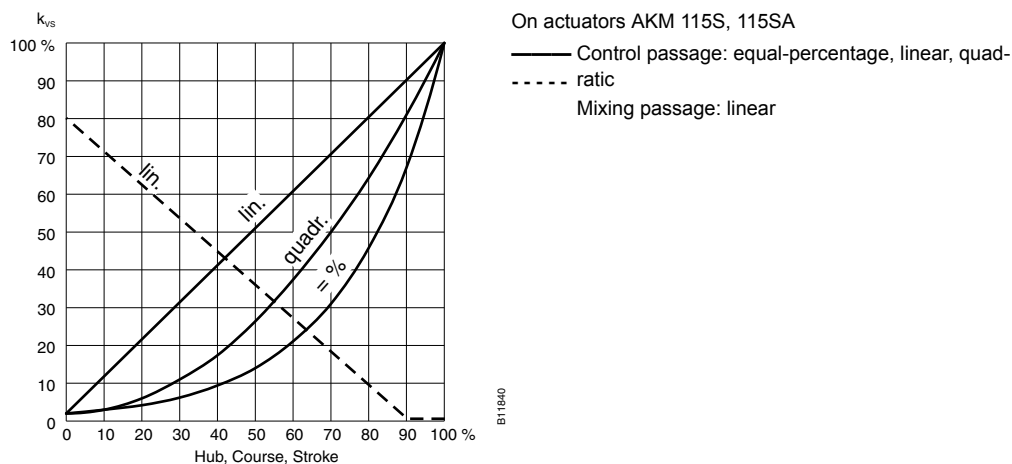

Disposal

When disposing of the product, observe the currently applicable local laws. More information on materials can be found in the Declaration on materials and the environment for this product.

Dimension drawing

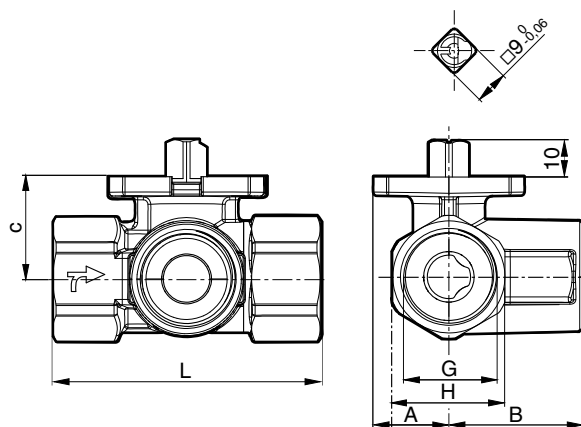

DN	A (mm)	B (mm)	c (mm) NPT	G (inch)	L (mm) ISO 7/1 Rp	H (mm)
15	21	34	24 (28) ²⁾	Rp 1/2	67	26
20	21	37	28	Rp 3/4	72	31
25	21	45	31	Rp 1	85	39
32	21	53	34	Rp 1 1/4	99	48

²⁾ 28 mm for variant BKR015F310-FF

DN	A (mm)	B (mm)	c (mm) NPT	G (inch)	L (mm) ISO 7/1 Rp	H (mm)
40	21	57	40	Rp 1½	110	55
50	21	69	53	Rp 2	131	67

Combinations

i All dimensions in mm.

i For dimension c, see table above.

AKM 105, 115(S), 115SA³⁾

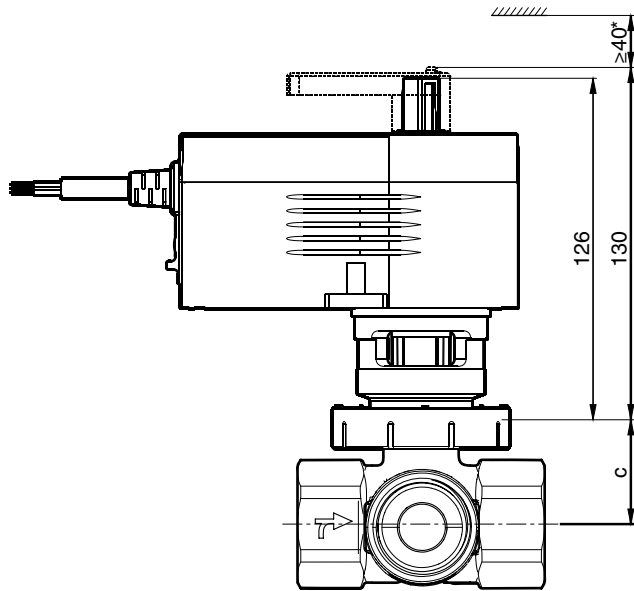

*) with auxiliary change-over contacts 0510480001 or 0510480002: ≥ 72 mm

AKF 112, 113(S)

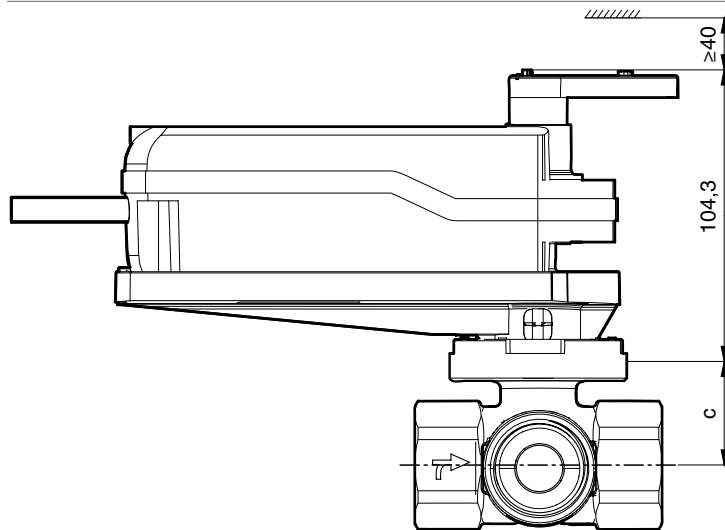

³⁾ Observe length of AKM 115SA (see PDS 53.100)

Accessories

05603320**	DN	b (mm)	c (mm)	G (inch) ISO 228-1	L (mm)	H (mm)
	15	12	38	G ½	54	27
	20	15	43	G ¾	67	34
	25	16	53	G 1	79	41
	32	17	64	G 1¼	98	51
	40	18	70	G 1½	106	57
	50	20	85	G 2	122	69

05602840**	DN	b1 (mm)	b2 (mm)	G1 (inch) ISO 228-1	G2 (inch) ISO 7-1	L (mm)	H1 (mm)	H2 (mm)
	15	10	10	G ½	Rp ½	46	26	30
	20	12	12	G ¾	Rp ¾	52	31	37
	25	14	14	G 1	Rp 1	60	40	46
	32	16	16	G 1¼	Rp 1¼	65	50	54
	40	17	17	G 1½	Rp 1½	76	54	64
	50	20	20	G 2	Rp 2	98	69	81

All dimensions in mm.

0510420001	0510240011